



APPLICATION OVERVIEW:

A leading manufacturer of full-suspension mountain bikes has developed one of its most innovative bikes to date.

>> [Learn more about iglide® plastics bushings](#)

>> [Subscribe to e-newsletter](#)

>> [Contacts in your location \(on-site within 24-48 hours\)](#)

>> [Request catalogs / free samples](#)

>> [myigus](#)

>> [myCatalog](#)

igus Inc.

PO Box 14349

East Providence, RI 02914

P. 1-800-527-2747

F. (401) 438-7270

sales@igus.com

www.igus.com

CASE STUDY

FULL SUSPENSION MOUNTAIN BIKE

Lightweight and corrosion resistant

A leading manufacturer of full-suspension mountain bikes has developed one of its most innovative bikes to date. Triple-buttressed tubing gives added strength to the joints, while the carbon-fiber frame is lightweight, corrosion resistant, and strong.



Pivot points play an important part in rear-suspension design

On the two front pivot points, between the swing arm and the frame, deep-groove ball bearings are used, because the bearings have to execute a relatively large swiveling motion. At the rear joint, on the rear axle, an iglide® J plastic bushing from igus® has been implemented.

The plastic bushing has a much larger contact area than a roller bearing. This means that, even under extreme stress and lateral forces, it doesn't wobble.

Selecting the optimal plastic bushing material

Originally, "[iglide® G300 plastic bushings](#)" had been considered. Bushings made from this material are suitable for the widest range of applications and are low cost.

However, "[iglide® J](#)" provides greater dimensional stability when wet – a crucial parameter, if the bike goes through streams and puddles.

The plastic bushing is inserted into the swing arm and enclosed in a metal sleeve, which forms the end stop for tightening the screws.



The plastic bushing is inserted into the swing arm and enclosed in a metal sleeve, which forms the end stop for tightening the screws.

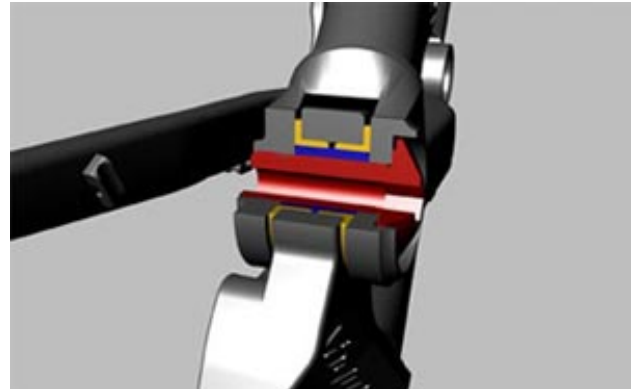

At the rear hinge, on the rear axle, the bike's designers took a new approach by using a plastic bushing with a much larger contact area than roller bearings.

Specialist dealers and bikers are fully satisfied

Dealers were extremely happy with the new solution because the feedback from bike owners turned out to be 100% positive. The torsional stiffness of the wheel is very good and the suspension responds very quickly.



iglide® J provides greater dimensional stability when wet – a crucial parameter, if the bike goes through streams and puddles.

Beijing and Athens Olympic wins

Olympics winner Sabine Spitz won a gold medal in the Beijing Olympics in 2008 on a mountain-bike with iglide® plastic bushings in the suspension fork. The polymer components stood up to the constant impacts, edge loads, and dirt on the extreme course at the Chinese Laoshan Velodrome.

At the Athens Olympics in 2004 Olympics, mountain bikers who had ridden bikes with lightweight, wear-resistant iglide® bushings built into the guide rollers of the derailleurs, were awarded gold, silver, and bronze medals.

More product information

[iglide® J plastic bushings](#)

[iglide® G300 plastic bushings](#)

More application examples & products for the bike industry

[Bicycle design](#)