

# TECHTALK DESIGN ADVICE SERIES

## BUTTING RAILS TOGETHER IN 5 EASY STEPS



Linear rails typically come in lengths between six and 12 feet (1829-3650 millimeters), but customers often ask: is it possible to make rails longer by butting them together?

The answer is yes and linear plain bearings, like igus®' line of DryLin® linear bearings and guides, are ideal for these types of applications.

Since linear plain bearings slide on a plane and “bridge” the gap in between the two rails, they are a better choice than a rolling-element bearing, for example.

At the onset, this task may seem simple – how difficult could lining up the ends of a few pieces of aluminum really be? However, it is very important that the rails are butted together correctly. Follow these five steps to make joining long lengths of rail a simple and easy task.

### Step 1 Measure



challenging if you are trying to match a brand new rail with one

Measure the two rails you plan to join. Keep in mind, it is not recommended to butt-together rails that differ in height or width by more than 0.002 inches (0.05 millimeters). This can be



### YOUR CONTACT



Matt Mowry

Product manager, DryLin®  
linear bearings and guides

[Mmowry@igus.com](mailto:Mmowry@igus.com)

>> [Subscribe to e-newsletter](#)

>> [Contacts in your location  
\(on-site within 24-48 hours\)](#)

>> [Request catalogs / free  
samples](#)

>> [myigus](#)

>> [myCatalog](#)

igus Inc.

PO Box 14349

East Providence, RI 02914

P. 1-800-527-2747

F. (401) 438-7270

[sales@igus.com](mailto:sales@igus.com)

[www.igus.com](http://www.igus.com)

purchased years ago because manufacturing tolerances vary from lot to lot between aluminum extrusions. In addition, there might be a variation in color.

So, ideally, it is best to use rails from the same manufacturing lot, or alternatively, use precision ground aluminum or steel shafting that have much tighter machined tolerances.

### Step 2 Cut

Cut the rails so that the bore spacing is symmetrical throughout the travel. For example, if the nominal distance between mounting bores is 120 millimeters (c4), then the distance from the end to the first holes on each end mating should be 60 millimeters (c5 or c6).



### Step 3 File

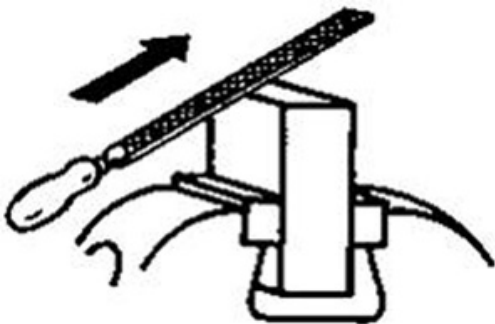

At the ends of each rail that will be joined, file a 30 - 45° x 0.5mm chamfer in all the surfaces that the bearing could contact. The filing can be done by hand. Make sure to de-burr afterwards. Please contact igus® if you would like us to quote this operation.

### Step 4 Align

Align each length of rail and fix loosely with screws.

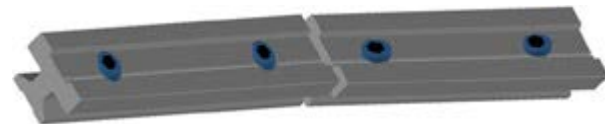

## Step 5

### Clamp and check

Before permanently fixing the rail assembly, align the rails with the help of clamps at the seam line and butt up against a straight-edge, if possible. Fix the screws and check the butt-joint to ensure the carriage(s) run smoothly over each joint. If the carriage does not run smoothly, you will need to realign the rails.

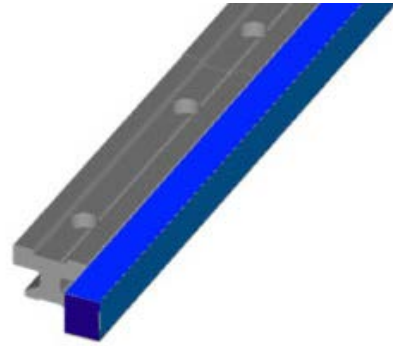

[Contact us](#)